



USER MANUAL

SPY RF U



06251H

# TABLE OF CONTENTS

---

<b>I.</b>	<b>INTRODUCTION.....</b>	<b>3</b>
a)	Equipment .....	3
b)	Symbols.....	3
<b>II.</b>	<b>INSTALLATION RECOMMENDATIONS .....</b>	<b>4</b>
a)	Perturbations sources .....	4
b)	Position .....	4
c)	Installation of wall-mounting bracket.....	4
<b>III.</b>	<b>PRESENTATION.....</b>	<b>5</b>
a)	Display .....	5
b)	Additional information.....	5
c)	Connector .....	5
d)	Locating connectors.....	6
e)	Wiring.....	6
f)	Connecting probes.....	6
<b>IV.</b>	<b>USE.....</b>	<b>6</b>
a)	Stop .....	6
b)	Start .....	7
c)	Waiting mode .....	7
d)	Configuration .....	7
e)	Measurement start.....	7
f)	Automatic start.....	7
g)	Manual start.....	8
h)	Alarm visualisation.....	8
i)	Measurement stop.....	9
j)	Auto control or top zone.....	9
k)	Leds and pushbutton actions functioning.....	9
<b>V.</b>	<b>BATTERY CHANGE .....</b>	<b>10</b>
<b>VI.</b>	<b>RESET .....</b>	<b>10</b>
<b>VII.</b>	<b>MAINTENANCE .....</b>	<b>10</b>
<b>VIII.</b>	<b>TECHNICAL CHARACTERISTICS .....</b>	<b>11</b>
<b>IX.</b>	<b>CAPACITY OF OPERATION DATA SHEET.....</b>	<b>12</b>
<b>X.</b>	<b>WARRANTY.....</b>	<b>13</b>
<b>XI.</b>	<b>MAINTENANCE CONTRACT.....</b>	<b>13</b>
<b>XII.</b>	<b>ENVIRONMENT PROTECTION.....</b>	<b>13</b>

## I. INTRODUCTION

Congratulations, you own a SPY RF U (Universal) ! This device is equipped with 1 or 2 inputs (analog or logical...). It enables you to record 1 or 2 physical parameters (depending on the model) and to transfer wirelessly the recorded data by radio frequency to Sirius software installed on a PC through to a SPY RF Modem managed by Sirius.

**The SPY RF U complies with EN 12830, only with temperature probes and with EN 13486**



### a) Equipment

- 1 SPY RF U1 (1 input) or U2 (2 inputs)
- 1 wall-mounting bracket
- 1 adhesive plaster
- 1 PT100 sensor (depending on the model)
- 1 Gauging certificate (depending on the model)
- 1 connector protection
- 1 user manual

### b) Symbols

	<i>RECYCLING: do not throw in a rubbish dump or in a domestic waste container. Comply with current regulation to throw away the device.</i>
	<i>Power : This unit is power by a lithium AA battery in 3.6VDC-10µA.</i>
	<i>CE MARKIN : this equipment is certified to comply with the European regulation for the electric security, inflammability, disturbing radiation emission and immunity to surrounding electric disturbances.</i>
	<i>FCC ID : W45 03330 This device complies with Part 15 of the FCC Rules. Operation is subject to the following two conditions: (1) this device may not cause harmful interference, and (2) this device must accept any interference received, including interference that may cause undesired operation In accordance with FCC requirements, changes or modifications not expressly approved by JRI could void the user's authority to operate this product. NOTE: This equipment has been tested and found to comply with the limits for a Class A digital device, pursuant to Part 15 of the FCC Rules. These limits are designed to provide reasonable protection against harmful interference when the equipment is operated in a commercial environment. This equipment generates, uses and can radiate radio frequency energy and, if not installed and used in accordance with the instruction manual, may cause harmful interference to radio communications. Operation of this equipment in a residential area is likely to cause harmful interference in which case the user will be required to correct the interference at his own expense.</i>



- **Do not use the unit in conditions other than those described in the technical**
- **Risk of fire or explosion in the event of misuse:**
  - Charging the battery
  - Short-circuit the battery
- **If the unit is used in a manner not specified by the manufacturer, the protection provided by the equipment may be compromised.**

## II. INSTALLATION RECOMMENDATIONS

The SPY RF is a recorder of physical parameters able to communicate in radiofrequency with the operating software SIRIUS thanks to a SPY RF ModeM. . To guarantee optimal radio transmission, it must meet a number of recommendations, as any wireless transmission is subject to disturbances

### a) Perturbations sources

- Presence of obstacles in the way of the waves between the SPY RF ModeM and the SPY RF (wall, ceiling, person, furniture...) or close to the antenna.
- Obstacles thickness in the way of the waves. The absorption is more important in diagonal as perpendicularly

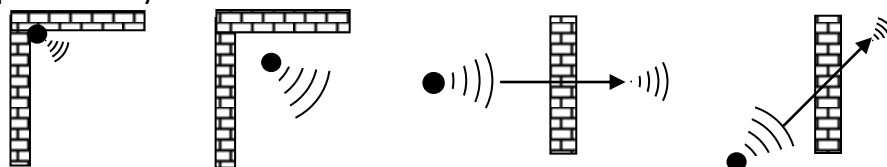

- Waves cannot pass through full metallic walls. On the other hand, a perforated wall allows the waves passing with attenuation

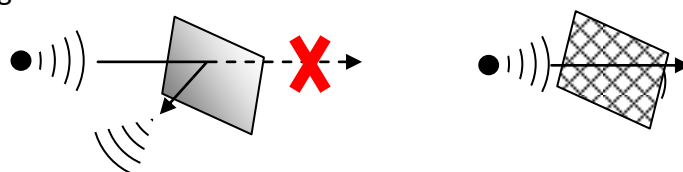

### b) Position

- Place the devices at ~2m high and around 30 to 40cm from the ceiling to avoid obstacles and moving persons.
- If possible, place the SPY RF in central position regarding the SPY RF recorders.
- Try to place them preferably at sight of each other.
- On the wall, it is preferable to them aside by using the special bracket (ref 08708) of the catalog.
- Place the antenna above the top the monitored unit (fridge, incubator, oven, cold rooms...).
- Never place the SPY RF horizontally.
- If some difficulties persist, it is possible to use SPY RF RelaY (repeaters) or to connect another SPY RF ModeM to the Ethernet network (LAN).



**To ensure your safety during installation or intervention on a device at this height (2m), use a stable means to and in good used condition, wear suitable footwear and non-slippery and install security markup if intervention takes place in a place of passage.**

### c) Installation of wall-mounting bracket

The bracket can be fixed thanks to its adhesive plaster or it can be screwed.

- Screwing map

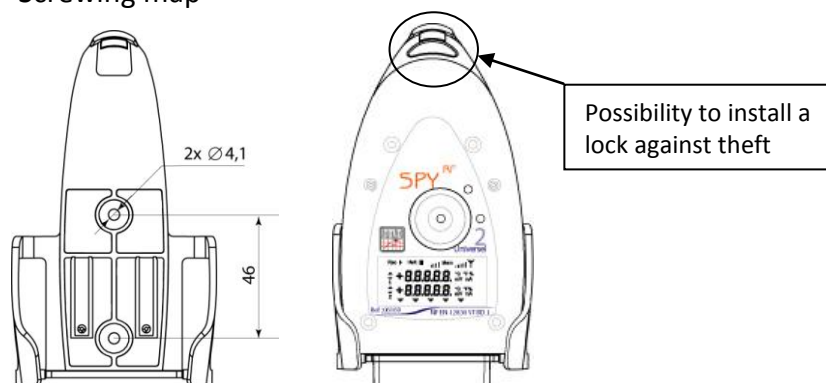

### III. PRESENTATION

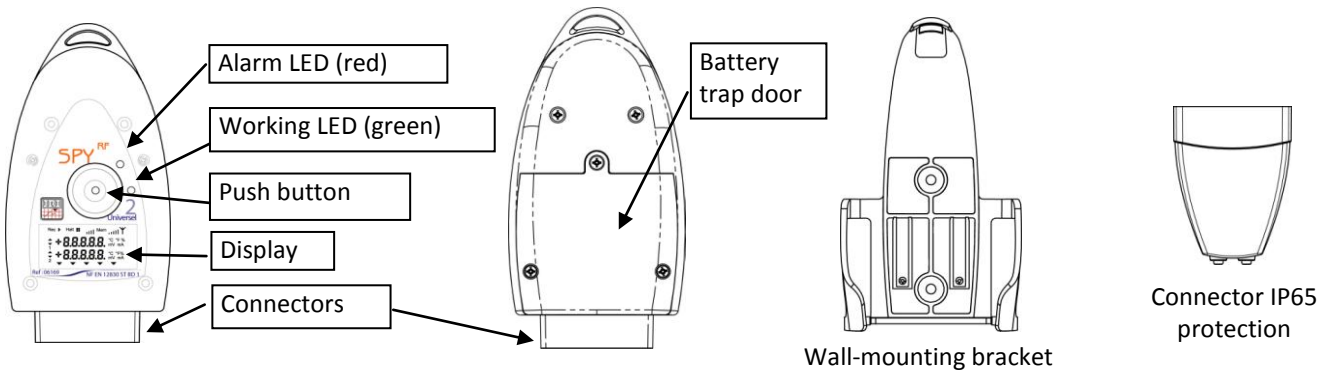

#### a) Display

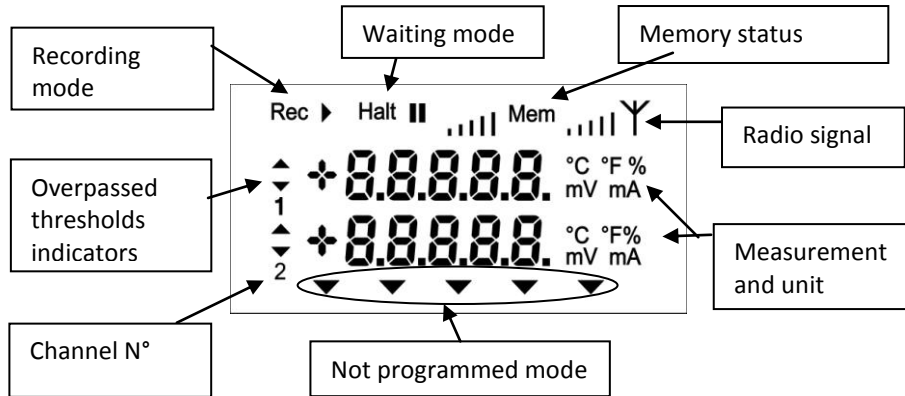

#### b) Additional information



Full memory. You must transfer the data to your PC.



Low battery. You must change the battery (See "battery change p22)

#### c) Connector

The SPY RF U is equipped with rapid connectors which make the installation of different type of probes very easy. The probes can otherwise be disconnected from the recorder to be changed or to change the recorder itself.

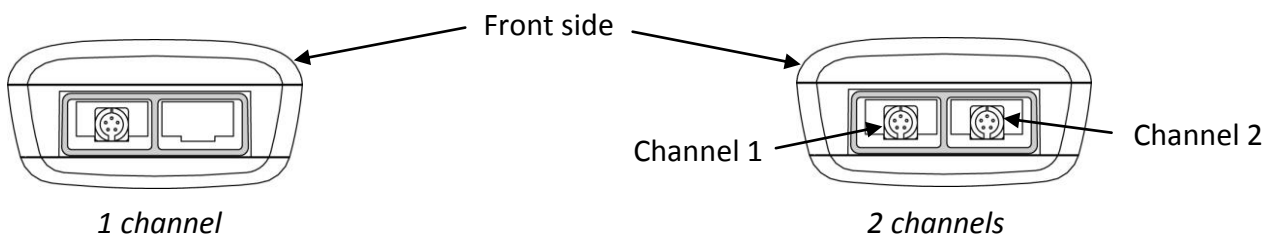

**d) Locating connectors**

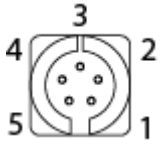

Male connector on  
SPY RF U

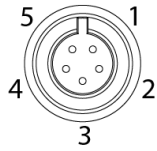

Female connector on  
the probe cable (side

- 1 N/C
- 2 Power output for resistive sensors
- 3 Analog input to measure resistance, voltage or current
- 4 Digital or counter frequency input  
Dry contact start input
- 5 Ground

**e) Wiring**

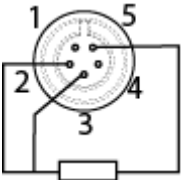

Resistive probe  
input

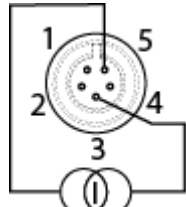

Current input  
4-20mA

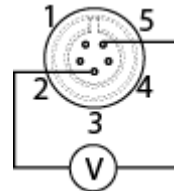

Voltage input  
0-1V

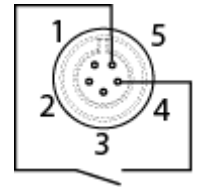

Frequency, count, or  
logical input

**f) Connecting probes**

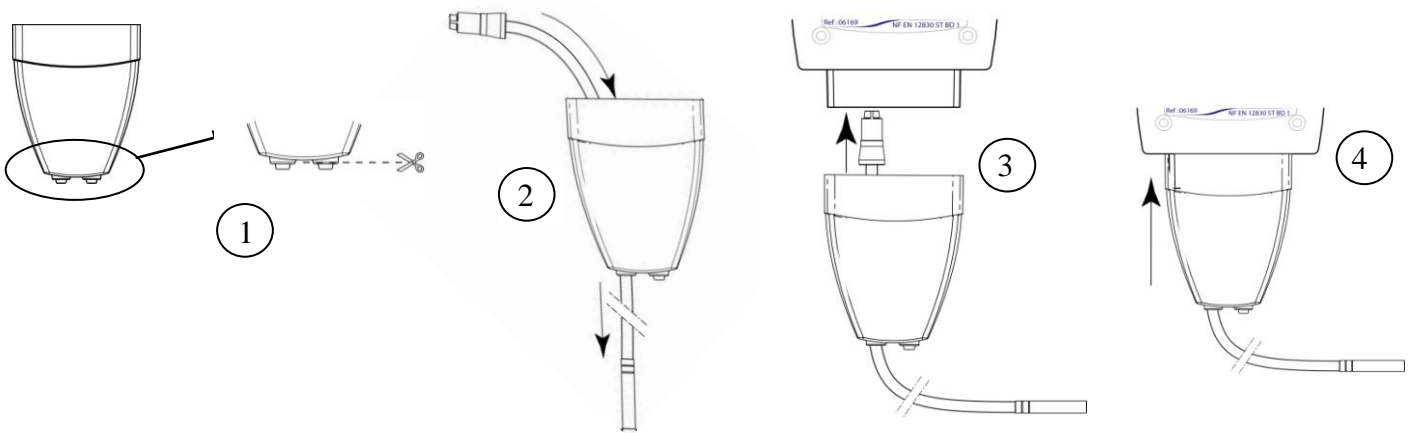

**Never unscrew the sensor connector to unplug it. Pull out strongly.**

**IV. USE**

The SPY RF can only be used with a Sirius software issue installed on a PC or server and a RF Modem Spy. (refer to the manual of Sirius to know the minimum system requirements)

**a) Stop**

When you receive it, your SPY RF is stopped. Only the time clock is active. It can neither emit nor receive anything.

## b) Start

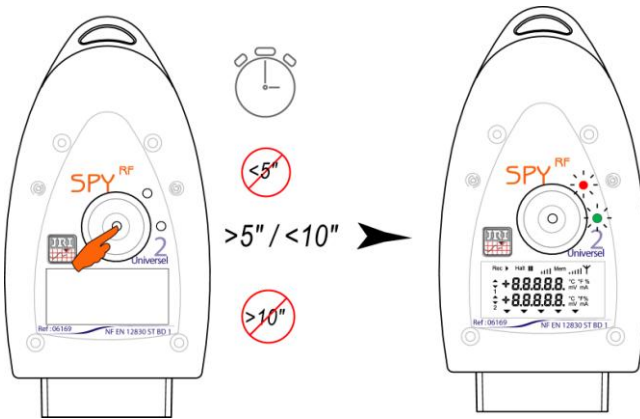

To start your SPY RF, please press between 5 and 10" on the button:

the 2 LEDs are on and flash at the same time

- all the display segments are also on

- the SPY RF is now in waiting mode

**Remark: If you press >10" => no effect => remains off**

## c) Waiting mode

The SPY RF is ready to receive a configuration or to start a new recording session.

The symbol "Halt" is on: no measures in progress.

Use the pushbutton to start.

## d) Configuration

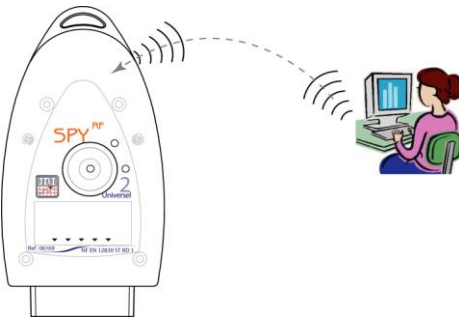

SPY RF configuration is done from the Sirius software (see Sirius user manual) and then transferred into your SPY RF by radio frequency thanks to a SPY RF Modem.

## e) Measurement start

The SPY RF has 2 starting mode:

automatic start

manual start

## f) Automatic start

Your SPY RF starts recording:

- automatically when the configuration is transferred,

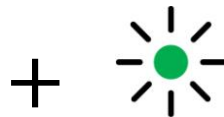
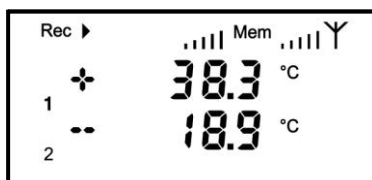

Working LED (green):  
2" => starting measurements  
then flashes every 1 minute

It displays the temperature in °C degrees, channel number, measurement unit and memory status.

The green LED flashes every minute.

The temperature, threshold indicator, channel number and a red LED flashes every 15 sec in case the threshold limit is overpassed.

- at a programmed date and time:



dd / mm / yy  
hh / mm / ss

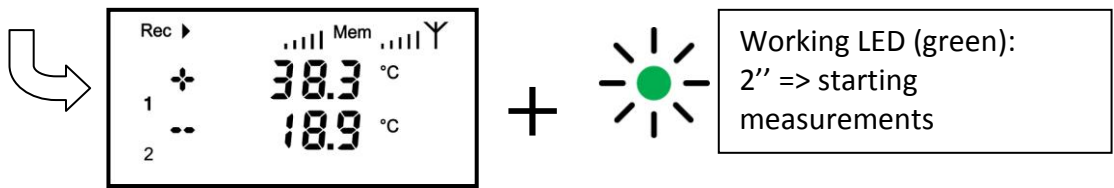

- by the change of a logic input (on channel 2)

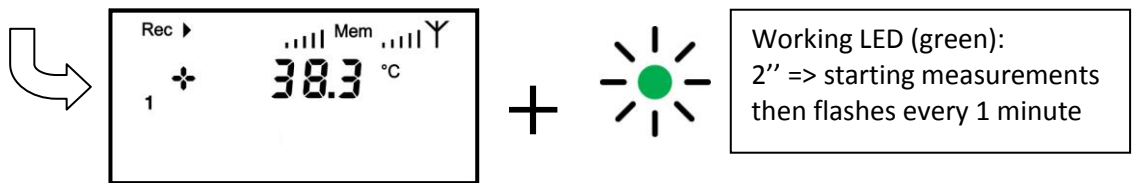
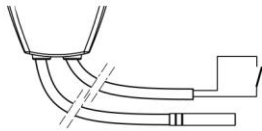

### g) Manual start

Press shortly on the pushbutton

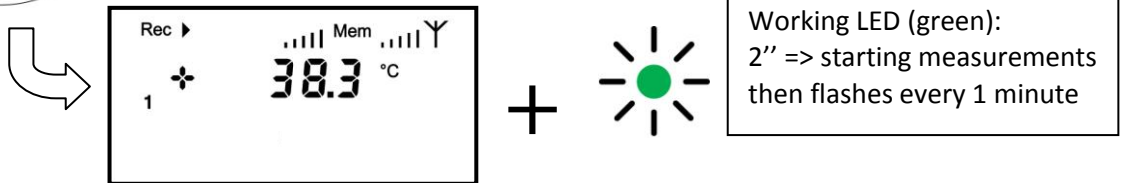

It displays the temperature in °C degrees, channel number, measurement unit and memory status.

The green LED flashes every minute.

### h) Alarm visualisation

The SPY RF is equipped with different alarm indicators, when a threshold limit is overpassed.

Pre alarm



Alarm

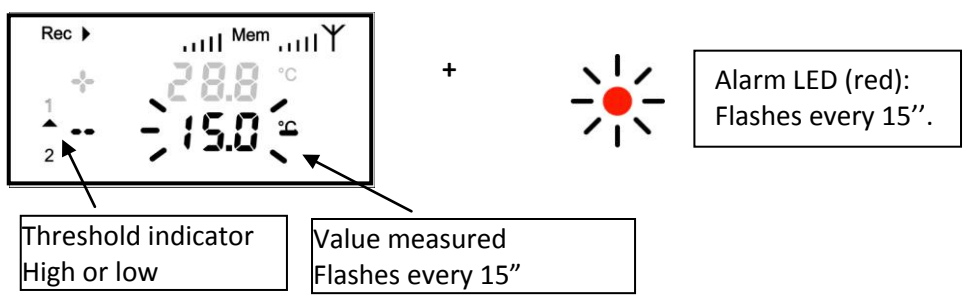



**i) Measurement stop**

Depending on the configuration, the SPY RF can stop recording or not. The different options are:  
 Rolling memory: once the memory is full, the new values replace the old ones.  
 Full memory: the recorder stops when its memory is full.  
 With the software: you can put the SPY RF in standby mode with Sirius when you do not use your recorder.  
 With the pushbutton: this option is valid only if the SPY RF is configured in transport mode with a start by pushbutton

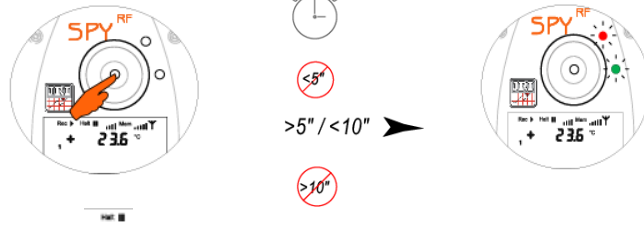

To stop your SPY RF, press between 5 and 10" on the button:

- The 2 LEDs are on and then flash alternatively.
- The screen goes off, Halt goes on.

**j) Auto control or top zone**

The type of action depends on the SPY RF configuration.  
 TOP ZONE = Transport mode and AUTO CONTROL = Storage mode  
 This function enables you to customise an action of measurement check-up. You just have to press shortly on the pushbutton.

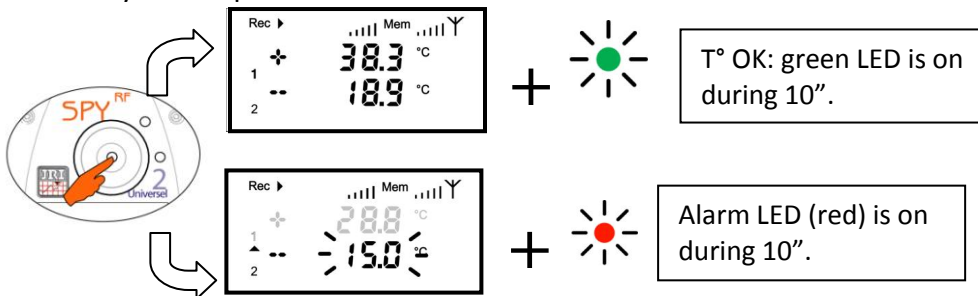

The action is recorded and will appear on the curve when you process the data with your software Sirius

**k) Leds and pushbutton actions functioning**

The green led is on 2" when the measurement starts and then flashes each 1' in recording mode. Specials functioning regarding the recorder using mode:

Device set up in storage mode

Mode	Pushbutton pressing	< 5"	5"> pressing <10"
OFF		-	<b>The 2 leds are on and flash at the same time.</b>
Starting measurements			
↓ Pushbutton		Green led 2" = beginning of measurements	-
↓ Delayed (date & time)		-	-
↓ Immediately		-	-
Mesure		Green led 10" = auto control	-

## Device set up in transportation mode

Mode	Pushbutton pressing	
	< 5"	5"<pressing>10"
Off	-	The 2 leds are on and flash at the same time.
Starting measurements	Green led 2" = beginning of measurements	-
	Delayed (date & time)	The 2 leds are on and flash at the same time = Waiting for starting measurements
	Immediately	The 2 LEDs are on and then flash alternatively = ending measurements
Mesure	Green led 10" = Top zone	The 2 LEDs are on and then flash alternatively = ending measurements

## V. BATTERY CHANGE

When the SPY RF battery has to be replaced, the LCD screen displays the following message:



**DOWNLOAD THE MEMORY BEFORE CHANGING THE BATTERY. NEVER WAIT UNTIL THE BATTERY IS EMPTY OR THE DATA WILL BE DELETED.**

To replace the battery, follow the instructions below:

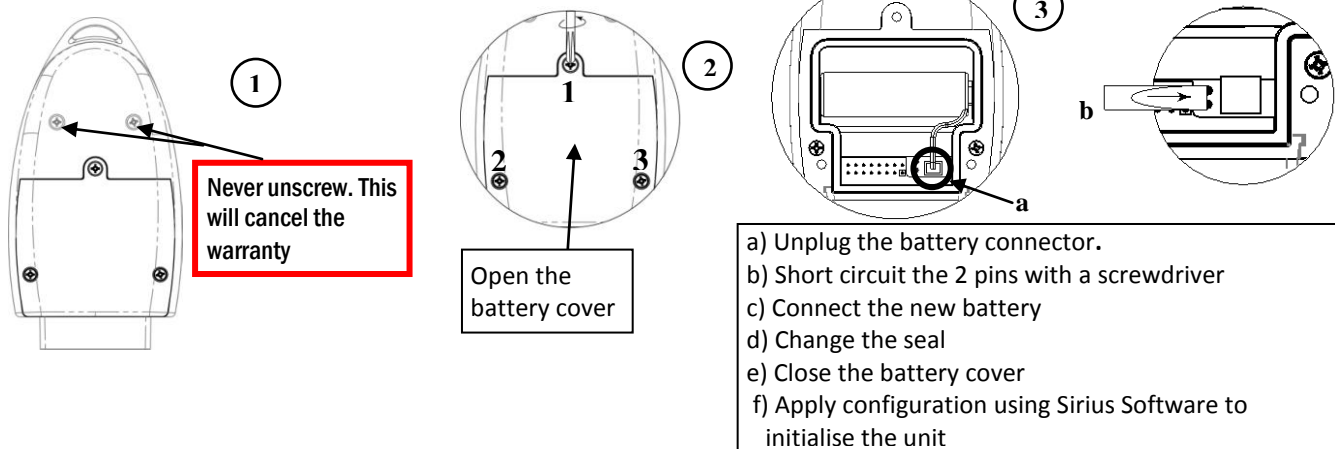

**KEEP THE BATTERY FAR FROM THE FIRE; DO NOT TRY TO RELOAD OR TO SHORT CIRCUIT IT. USE ONLY BATTERIES SUPPLIED BY JRI (REF 06569)**

## VI. RESET

If the device does not work anymore (cannot turn it on...), use the Reset function in the same way as the battery change.

## VII. MAINTENANCE

Clean with a soft cloth, dry or lightly moistened with water. To remove stubborn dirt, use a soft cloth impregnated with a mild detergent, non-abrasive. Then wipe gently with a soft, dry cloth. Never use benzene, thinners, alcohol or solvents of any kind, which may cause discoloration or deformation of surfaces

## VIII. TECHNICAL CHARACTERISTICS

FEATURES	SPY RF U
Measurement range	Depending on the sensor T° (-200 +400°C)
PT100 supplied*	-50 +105°C
Number of channels	1 or 2
Type of input	PT100/PT1000/4-20mA/0-1V/ TOR
Accuracy at 23°C	
Device without T° sensor	±0,3°C sur tte la plage (+probe EMT)
With T° sensor**	±0,20°C from -20 to +50°C and ±0,5°C outside
Current input 0-20 ou 4-20 mA	
resolution:	0,001 mA
accuracy (SPY IP alone):	± 0,01 mA
Voltage input 0-1V	
resolution:	0,1 mV
accuracy (SPY IP alone):	0,5 mV
Recording interval	1s to 90 min
Memory size	20 000 measurements
Operating conditions	-30 +70°C
Temperature for storage	-40 + 85°C
Radio range (in free field)	1 km
Radio band	868MHz or 902MHz
Battery lifetime	2 years
Dimensions	123x69x30mm
Protection degree	IP65
Classification IK	IK03
EN 12 830 compliance	Yes : this device must be regularly checked according to EN 13 486 (1 time per year recommended)
CE ERM compliance	EN 301 489 / EN 61000 / EN 61010 EN 55022 / EN 300 220
FCC compliance	FCC part 15

\* PT100 cIB molded with flat cable    \*\*Gauging report supplied

# JULES RICHARD INSTRUMENTS

## Fiche d'aptitude à l'emploi selon la norme NF EN12830

*Capacity of operation compliant to EN12830*

**Modèle / model:** Spy RF U  
**Type de matériel / equipment type :** enregistreur de température / temperature recorder  
**Utilisation / application :** stockage / storage  
**Classe de précision / accuracy class:** 1

**Tableaux des essais / Test table**

Essais / Test	§ norme / § norm	Car. minimales / Minimum specs.	Documents ou rapports d'essais / Document or test report
Détermination de l'erreur de la mesure de la température. <i>Temperature error measurement</i>	5.3	±1°C	Procès verbal d'essais JRI : REMT6009 <i>JRI test report</i>
Détermination du temps de réponse. <i>Temperature response time</i>	5.4	<20min	Procès verbal d'essais JRI : REMT6011 <i>JRI test report</i>
Détermination de l'erreur relative de l'enregistrement du temps. <i>Recording time error</i>	5.5	0.1%	Procès verbal d'essais JRI : RQCC06001 <i>JRI test report</i>
Variation de la tension d'alimentation. Enregistreur soumis aux températures assignées <i>Effect of power supply variations</i>	5.6.2	3V à 3,6V +5°C et +40°C	Procès verbal d'essais JRI : RQCC06002 <i>JRI test report</i>
Influence de la température ambiante (temp. limites) <i>Influence of ambient temperature on measurements</i>	5.6.3.3	0°C à +50°C	Procès verbal d'essais JRI : REMT6013 <i>JRI test report</i>
Essai de température avec l'enregistreur en condition de stockage et de transport. <i>Temperature test in storage/transport conditions</i>	5.6.4	-20°C à +60°C	P.V. d'essais JRI : REMT6015 <i>JRI test report</i>
Résistance aux chocs. <i>Shock tests</i>	5.6.5	EN 60068-2-27	P.V. d'essais EMITECH : RQ-05-60797 <i>Emitech test report</i>
Vibrations mécaniques. <i>Vibration tests</i>	5.6.6	EN 60068-2-27	P.V. d'essais EMITECH RQ-05-60797 <i>Emitech test report</i>
Degrés de protection procurés par l'enveloppe. <i>Environmental protection</i>	5.6.7	IP55 EN 60529	Procès verbal d'essais JRI RECC6002 <i>JRI test report</i>
Sécurité électrique <i>Electric safety</i>	5.6.8	EN 61010-1	P.V. d'essais EMITECH : RS-05-40306-2-HLR-STD <i>Emitech test report</i>
Rigidité diélectrique. <i>Dielectric rigidity</i>	5.6.9	N.A.	
Compatibilité électromagnétique. <i>Electromagnetic compatibility</i>	-	Marquage CE	P.V. d'essais EMITECH : RC-05-40124-1-BPe—SG <i>Emitech test report</i>

**Pour Jules Richard Instruments**  
**Le Directeur Technique et Qualité :**  
*Technical and quality manager*

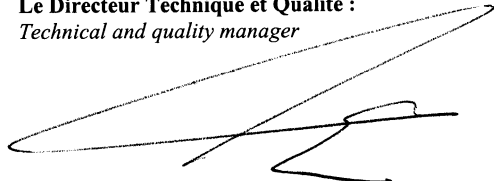

**Date :** 28/06/2006  
*date*

## X. WARRANTY

---

JRI products carry a one year warranty and guarantee against defects in their components or workmanship.

During this period if any product supplied by the Company proves on inspection to be defective, the Company will at its own option replace the same or refund to the Buyer the price of the product.

In no circumstances will JRI' liability exceed the price of the product paid by the buyer or the cost of replacement.

JRI shall not in any event be liable to the Buyer for any indirect or consequential loss or damage costs or expenses whatsoever which might arise out of or in connection with the supply of the product or its consequent use.

Consequently, the products warrantee and guarantee specified above, does not cover damage caused by fair wear and tear, abnormal storage conditions, incorrect use, accidental misuse, abuse, neglect, misapplication or modification, or use with non-JRI' hardware/software. No warranty of fitness for a particular purpose is offered and the user assumes the entire risk of using the product.

In line with our policy of continuous development, we reserve the right to amend our product specification without prior notice.

## XI. MAINTENANCE CONTRACT

---

### How to optimize your radio frequency installation?

RF measuring systems communicate by radio frequency. However, there may be several factors that can modify the radio ways already defined, such as moving from a building, adding walls, ... Radio frequency requires thus a periodical follow up performed by specialists.

That's why JRI has created maintenance contracts. We bring you a global solution which makes your maintenance easier. This overall service offer includes maintenance and also metrological services, which ensure you that your system is fully performant.

### You won't worry about your devices maintenance anymore!

With this maintenance contract you will benefit for a minimal period of 2 years from the following advantages:

- material verification once or twice a year
- warranty extension
- telemaintenance
- telephone assistance **+33 (0) 892 680 933** (0,282 € HT/min)
- material replacement on site or by return in our manufacture
- metrological certificates: verification of measurement accuracy
- battery change
- access to new software versions and updates
- on-site intervention time within 3 open days after problem identification by our experts

## XII. ENVIRONMENT PROTECTION

---

JRI recommends to our customers to throw away their measuring and recording devices which are unserviceable and/or beyond repair in a way that is appropriate to environment protection. Insofar as the production of waste cannot be avoided, it is best to re-use them by proceeding with adapted recycling depending on the material used and considering the environment protection.

### RoHS Directive

The ROHS European Directive rules and limits the presence of hazardous substances in electrical and electronic equipments (EEE).

In the article 2, the scope of this Directive excludes "9. Monitoring and Control Instruments" and our products are part of this category.

Nevertheless, our company has decided to apply the whole dispositions of this Directive for all our new electronic devices which will comply to this 2002/95/CE Directive.